

FEDERAL SUPPLY CLASS
5306

RATIONALE

DELETE RADIUS AT TRANSITION OF WRENCH FLATS AND BASE FLANGE, ADD EXISTING INVENTORY DISPOSITION NOTE, ADD "MINIMUM" TO FPI SENSITIVITY LEVEL REQUIREMENT, COLD ROLLING NOTE - DELETE CURRENT NOTE 4 (SEE AS7477) AND INCORPORATE LENGTH EXCEPTION INTO NOTE 3, DELETE REGARDLESS OF FEATURE SIZE SYMBOL FROM STRAIGHTNESS FEATURE CONTROL FRAME, CORRECT TYPOGRAPHICAL ERRORS IN K DIM MAX FOR -34,-35, AND -52, FIGURE 1 REDRAWN, GENERAL EDITORIAL UPDATE.

NOTICE

THE INITIAL SAE PUBLICATION OF THIS DOCUMENT WAS TAKEN DIRECTLY FROM U.S. MILITARY STANDARD MS9557E, AMENDMENT 2. THIS SAE STANDARD RETAINS THE SAME PART NUMBERS ESTABLISHED BY THE ORIGINAL MILITARY DOCUMENT.

ANY REQUIREMENTS ASSOCIATED WITH QUALIFIED PRODUCTS LISTS (QPL'S) MAY CONTINUE TO BE MANDATORY FOR DOD CONTRACTS. REQUIREMENTS RELATING TO QPL'S HAVE NOT BEEN ADOPTED BY THE SAE FOR THIS STANDARD AND ARE NOT PART OF THIS SAE DOCUMENT.

SAE Technical Standards Board Rules provide that: "This report is published by SAE to advance the state of technical and engineering sciences. The use of this report is entirely voluntary, and its applicability and suitability for any particular use, including any patent infringement arising therefrom, is the sole responsibility of the user." SAE invites your written comments and suggestions. SAE reviews each technical report at least every five years at which time it may be revised, reaffirmed, stabilized, or cancelled.

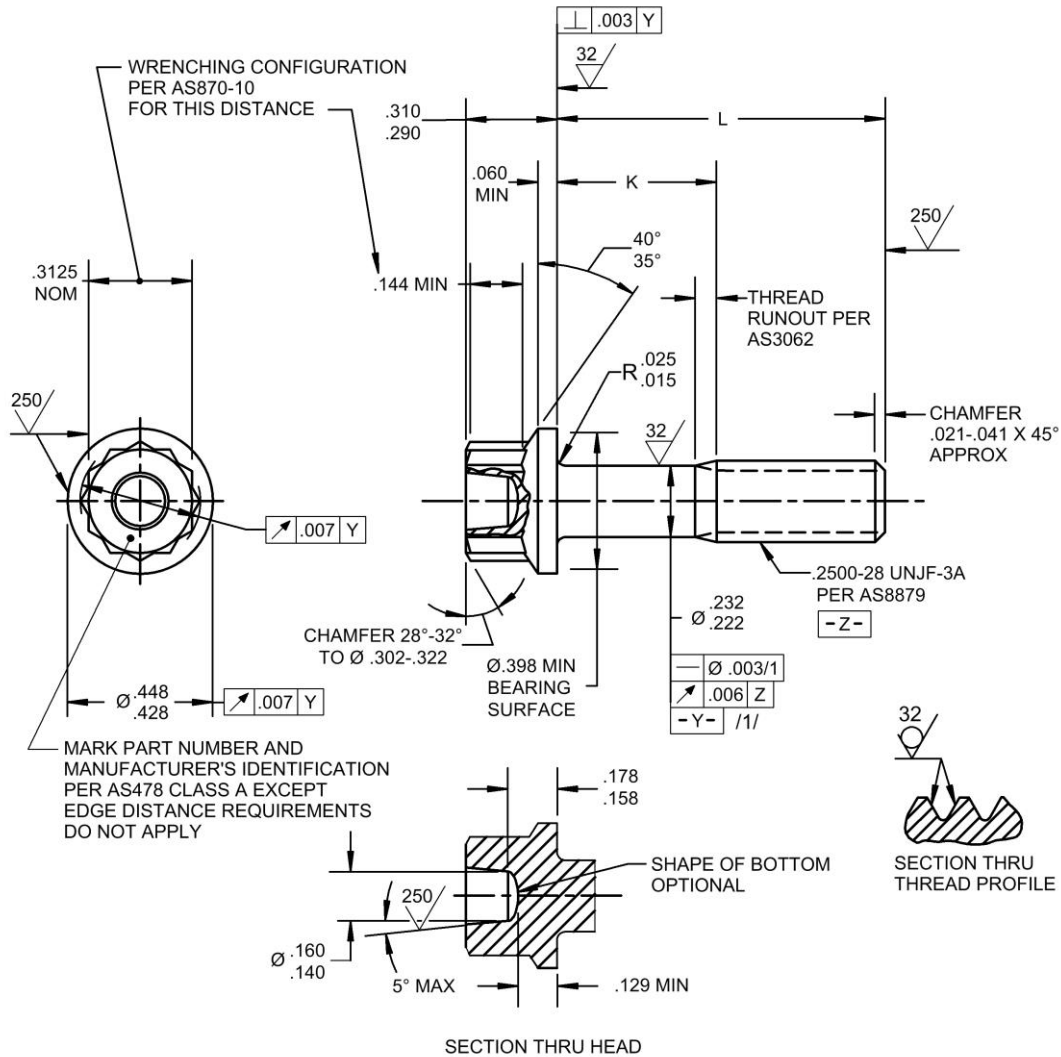
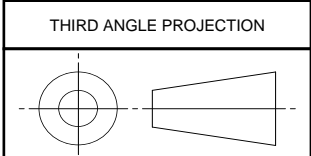

FIGURE 1 - BOLT

SAE values your input. To provide feedback on this Technical Report, please visit <http://standards.sae.org/AS9557E>



CUSTODIAN: E-25

PROCUREMENT SPECIFICATION: AS7477 /3/



AEROSPACE STANDARD

BOLT, MACHINE - DOUBLE HEXAGON EXTENDED WASHER HEAD, CORROSION AND HEAT RESISTANT STEEL, UNS S66286, UTS 130 KSI MIN, .2500-28 UNJF-3A

AS9557™
SHEET 1 OF 3

REV. E

ISSUED 2000-08 REVISED 2017-11